



TM

**VENIERI**  
SPA

**4.63H**  
**5.63D**

WHEEL  
LOADERS



**STAGE 5**



#### **4K LINKAGE.**

New completely redesigned linkage to the latest state of the art, for **maximum breakout force and interchangeability with previous versions.**



#### **AUTO SAFETY IS OUR PRIORITY.**

The **negative parking brake** is integrated into the front axle for maximum safety in all operative conditions *(optional on 4.63H).*



#### **SILENCE, PLEASE.**

Thanks to the new sound proof technology and special “anti vibration” rubber shock absorbers it was possible to reach **a deeply noise reduction inside cabin, for maximum comfort** for the operator.



#### **360° BREATHTAKING VIEW.**

The new cabin design guarantees **360° visibility**, for **complete working control** on each attachment installed granted the **best safety condition ever. Cabin level II ROPS/FOPS.**



#### **BE COOL.**

The **brand new ventilation system** grants an high level of operator comfort. With **VENIERI CLIMATRONIC** or thanks to new technological Air-condition you can find the perfect Enviroment inside your cabin.



#### **100% VENIERI DESIGN.**

In the new machines our **Venieri Design Lab** follows the “family feelings” but introduces significant **stylistic innovations.**





### **TOTAL STABILITY.**

Oscillating rear axle fixed to the frame with **maintenance-free** supports.



**AIR CYCLONE PRECLEANER**

### **ALWAYS CLEAN AIR.**

The new air cleaner system offers a **two stage filtration**, through **high efficiency primary filters** and **safety filters**, that could be integrate with cyclon pre-filter *(optional on 4.63H)* for maximum engine protection.



### **STAGE V/TIER IVf ENGINE.**

The **new Yanmar** and **Deutz engines** complies with the **latest emission standards** delivering **high torque** at low rpm.



### **DOUBLE ATTENTION FOR FUEL SAVING.**

The new electrically controlled **dual speed cooling fan**, adjusts the rotation speed according to the working conditions, **reducing fuel consumption and noise.**



### **BUILT FOR POWER, DESIGNED FOR AGILITY.**

The **special layout of the counterweight** grants **perfect maneuverability**, **maximum drive angle** and protection of the integrated rear lights in narrow spaces.

# 4.63H

## WHEEL LOADER "Z" LINKAGE



### DIESEL ENGINE

Inline-four cylinders, common-rail injection with electronic control, exhaust gas recirculation, water cooled, dry filtration, Diesel particulate filter (DPF). Engine complies with 97/68/CE - STAGE V/TIER IVf.

Type	Yanmar 4TNV98C	
Max. power	53 kW - 72 HP	
Rated rpm	2.500	
Power ISO/TR 14396	51,7 kW - 70 HP	
Power EEC 80/1269	51,7 kW - 70 HP	
<b>Economic working range (rpm)</b>	1200 - 1600	
Max torque	Nm	241
Bore	mm	98
Stroke	mm	110
Displacement	cm <sup>3</sup>	3.319



### ELECTRIC SYSTEM

Battery	12 Volt	
Capacity	110 Ah - 850 A	
Alternator rating	80 A	
Reverse warning	Standard	
Wiring accord to	IP 67 - DIN 40050	



### TRANSMISSION

Hydrostatic transmission with automatic power regulation and closed circuit with pumps and variable displacement engine. Two speed fwd/rev, with single-lever electronic control.

Speed	Forward	Reverse
1 <sup>st</sup> gear km/h	0 ÷ 7	0 ÷ 7
2 <sup>nd</sup> gear km/h	0 ÷ 30	0 ÷ 30

2<sup>nd</sup> gear automatic selection available as optional



### AXLES

Two heavy duty equal size axles with planetary final drives in each wheel. Fixed rigid drive axle. Oscillation rear axle on rear chassis section up to a total angle of 25°. Transfer gearbox transferring movement directly to the rear and to the front axle via transmission shaft.

Self locking limited slip differential on front axle.

Self locking limited slip differential on rear axle (optional).



### BRAKE

Service: hydraulic multi-disc oil brake on front axle working on all the wheels.

Parking brake: mechanical operating on service brake.



### TYRES

Standard	16/70 x 20
Optional	405/70 R20 • 14.5 x 20



### STEERING

Servo-assisted steering **LOAD SENSING** system.

Total steering angle	80°	
Inner tyres turning radius	mm	2.585
External tyres turning radius	mm	4.515
External bucket turning radius*	mm	4.980

\* Bucket on traveling condition



### HYDRAULIC SYSTEM

Two gear pump, the first for loader and steering circuit with **LOAD SENSING** valve, the second for the fan circuit with two rotating speed. Modular two-element control valve with main relief valve. Double acting hydraulic cylinders. Hydraulic oil cooling radiator. Full flow oil filter on the return line. Single lever arm to control 4 position lifting system and 3 position bucket system.

Max. flow	lt/1'	70
Max. flow with kit high flow (optional)	lt/1'	100
Loader relief valve pressure	bar	230
Steering relief valve pressure	bar	190
Lift cylinder	mm	80x585
Bucket cylinder	mm	85x395
Lifting time (full)	sec.	4.8
Lowering Time (empty)	sec.	3.7
Unloading Time	sec.	1.95
Total cycle time	sec.	10.45



### SERVICES CAPACITIES

Engine	lt	11
Front axle	lt	5,6
Rear axle	lt	5,8
Gear box	lt	3,8
Hydraulic circuit	lt	70
Brake circuit	lt	1,1
Fuel	lt	75
Water cooling	lt	15



### TECHNICAL FEATURES

Standard bucket capacity	m <sup>3</sup>	1,0
Bucket width	mm	2.000
Straight static tipping load	kg	4.600
Full turned tipping load	kg	4.200
Lifting capacity at max. height	kg	3.900
Hinge pin height	mm	3.260
Dump height at 41°	mm	2.550
Reach at 41°	mm	675
Breakout force	kg	5.600



### DIMENSIONS AND WEIGHT

Max. lenght in transfer position	mm	5.270
Max. width in transfer position	mm	2.000
Tyre external width	mm	1.873
Track width	mm	1.530
Wheel base	mm	2.275
Ground clearance	mm	330
Max height	mm	2.760
Standard operating weight	kg	5.400
Max permissible weight	kg	6.200



### dB NOISE LEVEL

Noise level inside cabin ISO 6396 - LpA	dB(A)	74
Exterior noise level ISO 6395 - LwA	dB(A)	98

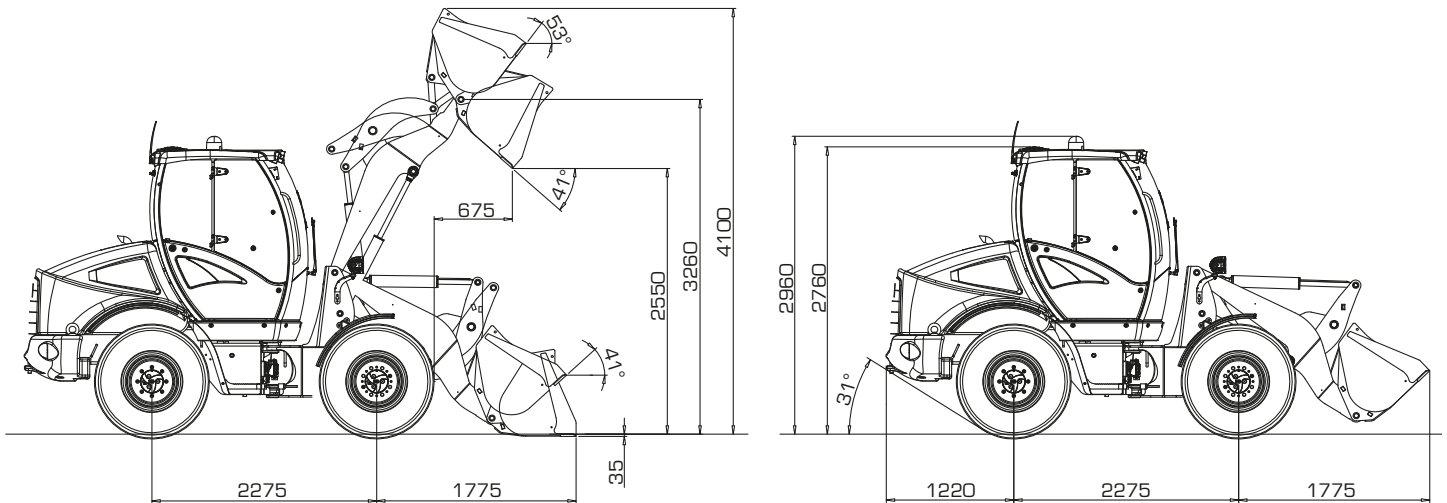
**PERFORMANCE DATA**

**UNIVERSAL  
BUCKET**

**MULTI PURPOSE  
BUCKET**

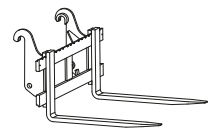
**OVERSIZE**

**FORKS**

Full load bucket capacity (SAE)	m <sup>3</sup>	1,0	0,9	1,5	/
Bucket width	mm	2.000	2.100	2.250	/
Bucket weight	kg	350	500	500	/
Overall operating height, fully raised	mm	4.100	4.050	4.155	/
Forks length (Standard)					1.000
Forks length (Optional)					1.200
Hinge pin height	mm	3.260	3.260	3.260	/
Dump clearance	°	41°	41°	41°	/
Dump height	mm	2.550	2.525	2.500	/
Dump distance	mm	675	650	725	/
Max dump distance	mm	1.425	1.375	1.475	/
Bucket static tipping load, straight	kg	4.600	4.800	4.350	/
Bucket static tipping load, full turn	kg	4.200	4.400	4.000	/
Forks static tipping load, full turn	kg				3.200
Payload EN 474-3 (80%) [•]	kg				2.560
Payload EN 474-3 (60%) [•]	kg				1.920
Breakout force	kg	5.600	6.100	5.200	/
Total length	mm	5.270	5.220	5.320	/
External bucket turning radius	mm	4.980	4.940	5.090	/
Standard operating weight	kg	5.400	5.550	5.400	/

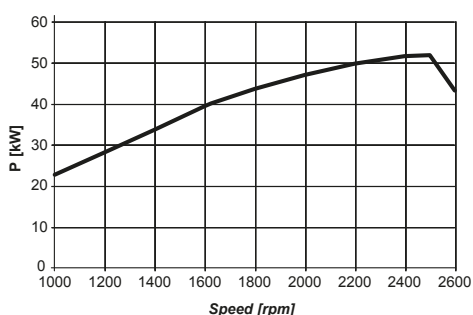
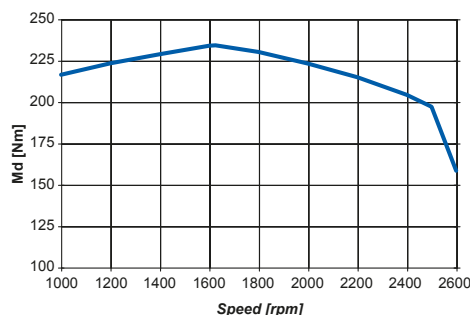
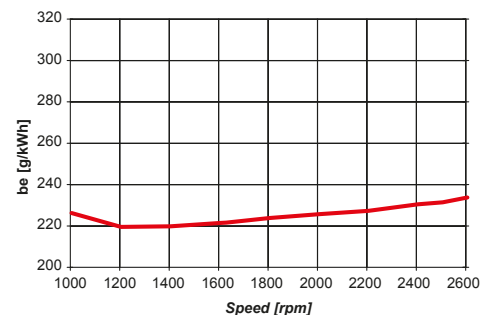
[•] Center of gravity 500mm

**POWER**

**TORQUE**

**FUEL CONSUMPTION**

# 5.63D

## WHEEL LOADER "Z" LINKAGE



### DIESEL ENGINE

Inline-four cylinders, turbocharged, common-rail injection with electronic control, exhaust gas recirculation, water cooled, dry filtration, Diesel particulate filter (DPF). Engine complies with 97/68/CE - STAGE V/TIER IVf.

Type	Deutz TD 2.9 L4
Max. power	58 kW - 79 HP
Rated rpm	2.600
Power ISO/TR 14396	55,4 kW - 75 HP
Power EEC 80/1269	55,4 kW - 75 HP
<b>Economic working range</b> (rpm)	1400 - 1800
Max. torque	Nm 260
Bore	mm 92
Stroke	mm 110
Displacement	cm <sup>3</sup> 2.925



### ELECTRIC SYSTEM

Battery	12 Volt
Capacity	110 Ah - 850 A
Alternator rating	95 A
Reverse warning	Standard
Wiring according to	IP 67 - DIN 40050



### TRANSMISSION

Hydrostatic transmission with automatic power regulation and closed circuit with pumps and variable displacement engine. Gearbox with 2 mechanical selections: 2 work speeds (fwd/rev) and 2 road speeds (fwd/rev).

Work speed	Forward	Reverse
1 <sup>st</sup> gear km/h	0 ÷ 4	0 ÷ 4
2 <sup>nd</sup> gear km/h	0 ÷ 11	0 ÷ 11

Road speed	Forward	Reverse
1 <sup>st</sup> gear km/h	0 ÷ 15	0 ÷ 15
2 <sup>nd</sup> gear km/h	0 ÷ 40*	0 ÷ 40*

\* Self limited max. speed



### AXLES

Two heavy duty equal size axles with planetary final drives in each wheel. Fixed rigid drive axle. Oscillation rear axle on rear chassis section up to a total angle of 25°. Transfer gearbox transferring movement directly to the rear and to the front axle via transmission shaft. Self locking limited slip differential on front axle. Self locking limited slip differential on rear axle (optional).



### BRAKE

Service: hydraulic multi-disc oil brake on front and rear axles. Parking brake: negative hydraulic on front axle, electrically applied.



### TYRES

Standard	405/70 R20
Optional	455/70 R20 • 14.5 x 20



### STEERING

Servo-assisted steering **LOAD SENSING** system.

Total steering angle	80°
Inner tyres turning radius	mm 2.585
External tyres turning radius	mm 4.515
External bucket turning radius*	mm 4.980

\* Bucket on traveling position



### HYDRAULIC SYSTEM

Two gear pump, the first for loader and steering circuit with **LOAD SENSING** valve, the second for the fan circuit with two rotating speed. Modular two-element control valve with main relief valve. Double acting hydraulic cylinders. Hydraulic oil cooling radiator. Full flow oil filter on return line. Single servo lever arm control with 4 position lifting system and with 3 position bucket system.

Max. flow	lt/1'	90
Max. flow with high flow (optional)	lt/1'	115
Loader relief valve pressure	bar	230
Steering relief valve pressure	bar	190
Lift cylinder	mm	85x580
Bucket cylinder	mm	90x402
Lifting time (full)	sec.	4.38
Lowering Time (empty)	sec.	3.41
Unloading Time	sec.	1.9
Total cycle time	sec.	9.69



### SERVICES CAPACITIES

Engine	lt	8
Front axle	lt	5,2
Rear axle	lt	6,2
Gear box	lt	1,8
Hydraulic circuit	lt	70
Brake circuit	lt	2
Fuel	lt	75
Water cooling	lt	15



### TECHNICAL FEATURES

Standard bucket capacity	m <sup>3</sup>	1,1
Bucket width	mm	2.100
Straight static tipping load	kg	4.950
Full turned tipping load	kg	4.400
Lifting capacity at max. height	kg	4.150
Hinge pin height	mm	3.360
Dump height at 40°	mm	2.685
Reach at 40°	mm	660
Breakout force	kg	6.400



### DIMENSIONS AND WEIGHT

Max. length in transfer position	mm	5.295
Max. width in transfer position	mm	2.100
Tyre external width	mm	1.937
Track width	mm	1.530
Wheel base	mm	2.275
Ground clearance	mm	330
Max. height	mm	2.760
Standard operating weight	kg	5.800
Max. permissible weight	kg	6.270

### dB NOISE LEVEL

Noise level inside cabin ISO 6396 - LpA	dB(A)	73
Exterior noise level ISO 6395 - LwA	dB(A)	100

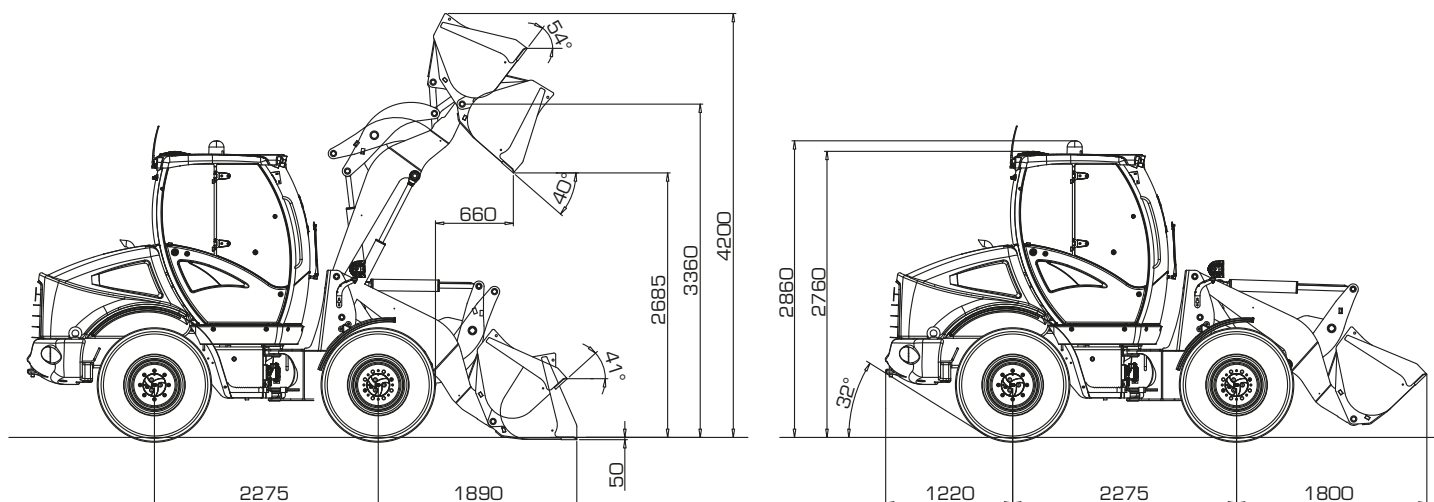
**UNIVERSAL  
BUCKET**

**MULTI PURPOSE  
BUCKET**

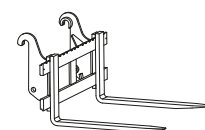
**OVERSIZE**

**FORKS**

**PERFORMANCE DATA**

Full load bucket capacity (SAE)	m <sup>3</sup>	1,1	0,9	1,5	/
Bucket width	mm	2.100	2.100	2.250	/
Bucket weight	kg	400	500	500	/
Overall operating height, fully raised	mm	4.200	4.145	4.250	/
Forks length (Standard)					1.000
Forks length (Optional)					1.200
Hinge pin height	mm	3.360	3.360	3.360	/
Dump clearance	°	40°	40°	40°	/
Dump height	mm	2.685	2.659	2.634	/
Dump distance	mm	660	635	710	/
Max dump distance	mm	980	930	1.030	/
Bucket static tipping load, straight	kg	4.950	5.150	4.700	/
Bucket static tipping load, full turn	kg	4.400	4.600	4.150	/
Forks static tipping load, full turn	kg				3.400
Payload EN 474-3 (80%) [•]	kg				2.720
Payload EN 474-3 (60%) [•]	kg				2.040
Breakout force	kg	6.400	6.890	6.010	/
Total length	mm	5.295	5.425	5.525	/
External bucket turning radius	mm	4.980	4.940	5.090	/
Standard operating weight	kg	5.800	5.900	5.800	/

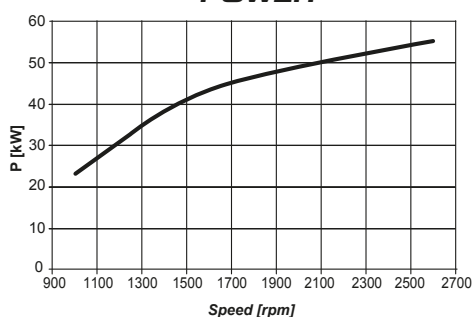
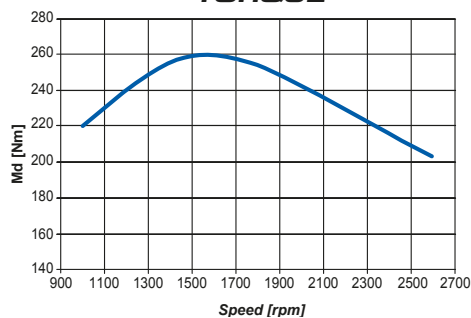
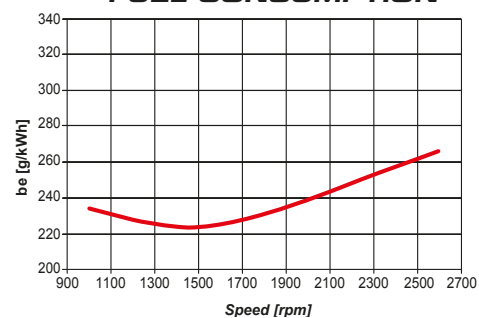
[•] Center of gravity 500mm

**POWER**

**TORQUE**

**FUEL CONSUMPTION**



# THE NEW CABIN

## A BREATHTAKING VIEW.

Take a seat in your customized control room. Create your ideal work space by **adjusting** the **pneumatic seat**\* and the **steering wheel** to suit your specific needs. Select the commands, **all at your fingertips**. Excellent **visibility to 360°** gives you the best view to work with maximum efficiency. The combination of **breathtaking cabin** and the **latest state of the art of 4K linkage** allows the **maximum control** of your attachments.

*\*Optional.*





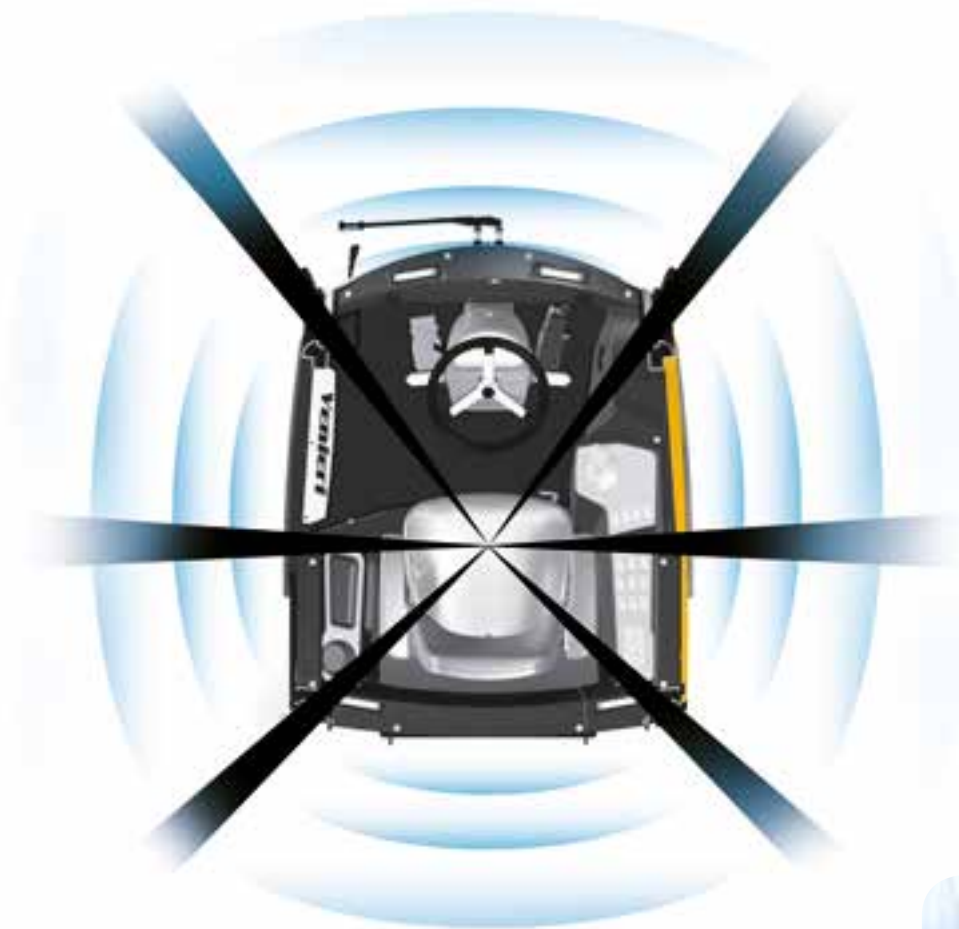

In the new 5.63D and 4.63H cabin we **minimized "blind spots"** for **superb visibility** in all working conditions.

### **OPEN SESAME!**

The **door with double opening** allows the operator to work with the entrance door closed, with top glass opened, ensuring **maximum ventilation** even with the A/C off and **without protruding parts out of shape**.



# 5.63D

## BEAUTY FINALLY MEETS FUNCTIONALITY.

The Venieri Design Lab, with the 5.63D new cab tried to merge **function** and **style** with the aim of become the best in the market. The new interior design has also allowed us to create different compartments useful for storing small tools, mobile phone, beverage, and more.



## ARTIFICIAL INTELLIGENCE.

**Advanced man/machine interface**, which constantly **monitors the performance of the machine** and communicates **each diagnosis** to the operator via a large and detailed LCD screen in the dashboard.

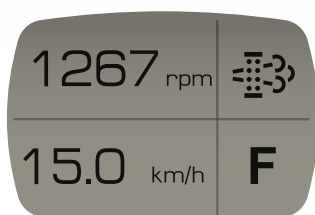

LAYOUT A

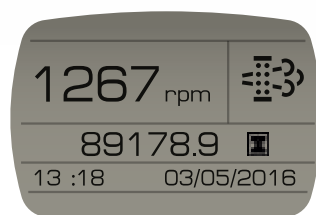

LAYOUT B

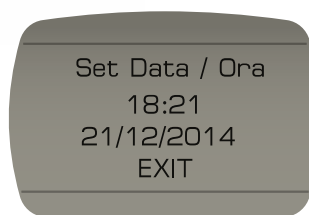

SETTINGS

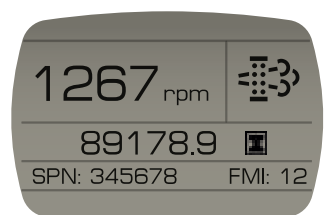

ENGINE ERROR



# 4.63H

**VENIERI STYLE.  
TOP LEVEL  
EFFICIENCY AND FUNCTIONALITY.**

Venieri Design Lab has redesigned the new cabin of 4.63H following the ambition to grant the best mix of **Italian style**, **design** and **functionality** even in a middle size loader range.

The **“Venierization”** of the interiors include the **yellow components** like a “nice to have” during your daily working process. Thanks to the new **Human/Machine interface** included in the **intuitive LCD** display, you can have a smart and constant control over the machine performances, **always connected to your Venieri.**



The brand new column steering system include the patented **adjustment control**, in order to fit exactly working/driving modes.





## BE COOL.

The entire ventilation system has been redesigned according to **ISO10263** also ensuring easy maintenance to the heating and A/C unit. Using a single dashboard, the operator can choose the ideal temperature, ensuring **maximum working comfort**.

The 5.63D and 4.63H can be equipped with **Venieri Climatronic**.

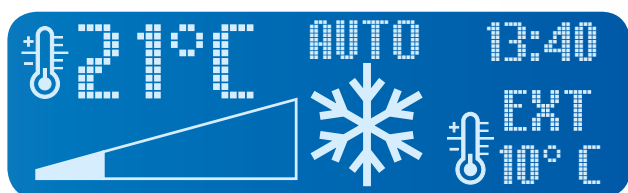
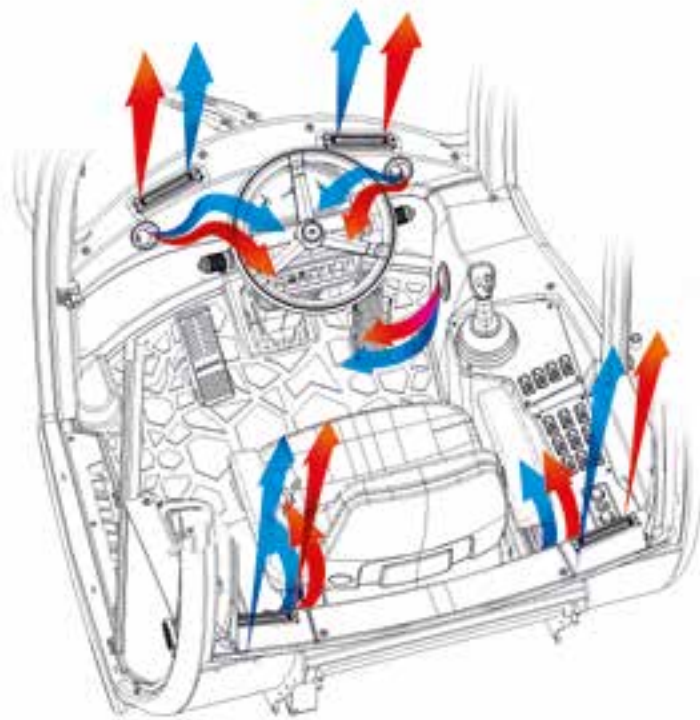

## THE BLACK BOX.

For the first time on a Venieri cabin, all electrical controls are positioned in a **waterproof** position accessible only from inside the cabin, easy to access and complete all diagnostics.

*(Photo: 5.63D)*

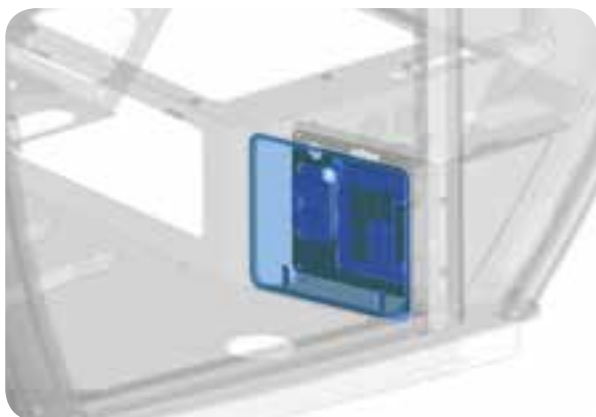

## ENJOY THE SHOW.

The driver's seat is equipped with the **most advanced solutions in terms of comfort** for maximum operational efficiency.



# CLASS EVOLUTION.

## CLEAN POWER, ZERO CONSUMPTION. NEW DEUTZ STAGE V/TIER IVf ENGINE

5.63D loader is powered by **the brand new Deutz Engine TD 2.9 L4**: inline four engine, 2.9 litres, ultra-compact, water cooled with DPF. This DPF **works with no additives, capturing the fine dust in the exhaust gases, and burning it during the automatic regeneration process, keeping filter clean with low operating cost.**

The **Common Rail** electronic injection system and the high efficiency combustion process with exhaust gas recirculation system, ensures **great performance with low fuel consumption, and low exhaust emissions.**



**5.63D** Deutz TD 2.9 L4  
58 kW - 79 HP

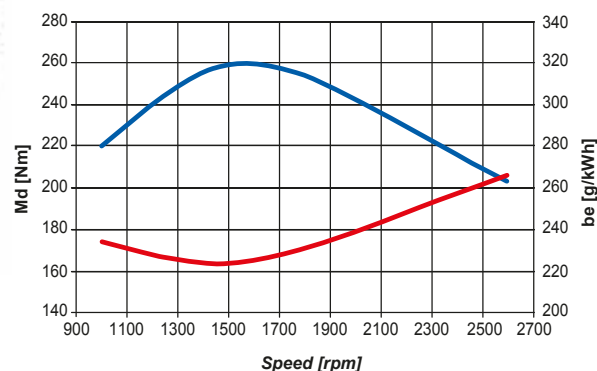
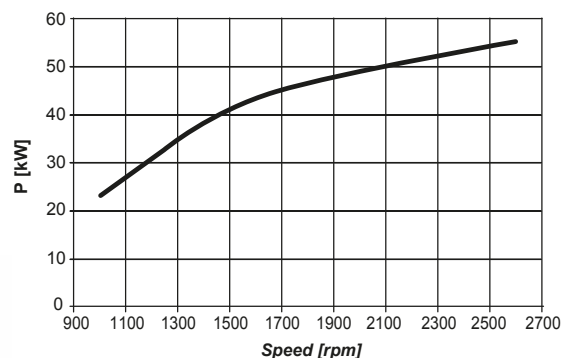

## JAPANESE TECHNOLOGY YANMAR ENGINE STAGE V/TIER IVf

The engine that equips the 4.63H is the **new Yanmar 4TNV98C**, a four cylinder unit of **3.319 cc** with **EGR system (Exhaust Gas Recirculation)** and **Diesel Particulate Filter DPF**; this has the peculiarity to operate without additives by capturing the fine dust of the exhaust gases and burning them during the automatic regeneration process, **keeping the filter clean** and keeping operating costs down. The DPF can work in three different modes: **assist regeneration, active regeneration, stationary regeneration.**

The Yanmar engine is equipped with a **Common Rail electronic injection system**, that grant an accurate control of the injection and combined with the exhaust treatment system, ensures **low fuel consumption** and reduces pollutant emissions.



**4.63H** Yanmar 4TNV98C  
53 kW - 72 HP

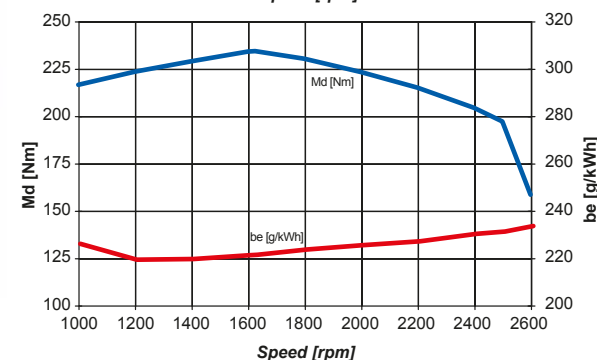
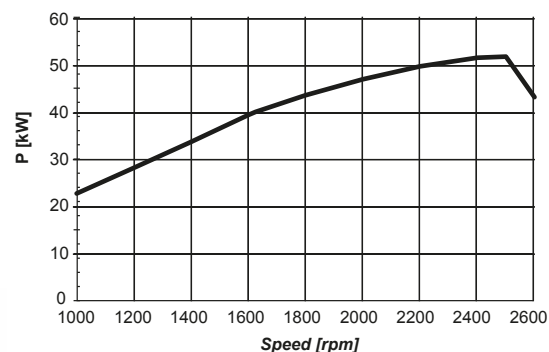

# Venieri GLOBAL

CONTROL YOUR FLEET

**Venieri GLOBAL™** is our brand-new satellite monitoring system, which guarantees an increase in productivity by providing detailed information about the fleet and attachments, as well as an incredible amount of data to ensure the highest performance levels and greater economic efficiency.

## A V A I L A B L E F E A T U R E S

Machine localisation	✓
Alerts history	✓
Maintenance plan	✓
Maintenance history	✓
Load information	✓
Working hours	✓
Security control (engine block)	0
Fuel consumption (total and partial)	✓
Fuel consumption while working	✓
Machine efficiency (while working)	✓
Detailed working hours	✓
Motion sensor alarm	✓
Curfew alarm setting	✓

Work shifts alarm	✓
Standard operating procedure history	0
Energy-saving guidelines history	0
Location log (map with locations and operating procedures)	✓
Information about diesel particulate filter	✓
Geo-fencing	✓
Localisation and management fleet	✓
Multiuser control with specific access policies	✓
List of "sleeping" machines	✓
Sms/e-mail notification	✓
Anti-theft alarm	✓
Parameters setting upon request	0

✓ Standad    0 Optional    X Not available

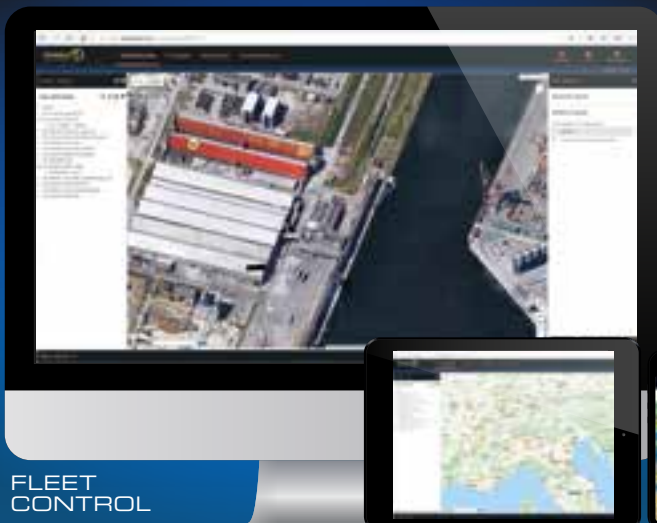

FLEET CONTROL

### PRODUCTIVITY REPORT

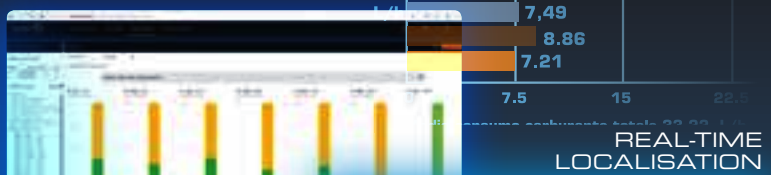

### REAL-TIME LOCALISATION



APP FOR SMARTPHONE  
IOS™ AND ANDROID™



**BASIC MACHINE**

Battery main switch	•	•
Tool box	•	•
Fuel preheating (cold climates)	0	0
Plugs with keys for fuel and hydraulic tanks	•	•
Proportional self lock front differential	•	•
Proportional self lock rear differential	0	0
Differential lock 100% engageable in front axle	0	0
Trailer coupling	•	•
Warning beacon	•	•
Soundproofing	•	•
Spare parts catalogue	•	•
User manual	•	•
Type-approval for road traffic	•	•
Safety clamp for bucket and lifting cylinders	•	•
Autolevelling ground level for bucket	•	•
Speed reduction kit	0	0
"Venieri GLOBAL" system	0	0
Double-speed hydraulic fan	•	•
Reversible fan (for radiator cleaning)	0	0
Hydraulic negative parking brake	0	•
Service brake on both axles with separate circuits	0	•
Inch pedal integrated in brake pedal	0	0
Greasing points grouped on the frame	•	•
Automatic centralized greasing system	0	0
Ride control	0	0
Engine preheating system	0	0
Environmentally-friendly hydraulic oil	0	0
Hydraulic oil ISO 46 (cold climates)	0	0
Cyclone dust separator	0	•
High speed Kit	0	-

**CABIN EQUIPMENT**

ROPS/FOPS 2nd Level, pressurized and soundproofed	•	•
Front and rear windscreen wiper with washer	•	•
Halogen work lights (4 front + 2 rear)	•	•
LED work lights (4 front + 2 rear)	0	0
Mobile phone compartment	•	•
Bottle holder	•	•
Document compartment	•	•
Seat with mechanical suspension	•	•
Seat with pneumatic suspension	0	0
Seat with pneumatic suspension and heating	0	0
Seat armrests	•	•
Buzzer	•	•
Cabin carpet	•	•
Clothes hangers	•	•
Radio preparation	•	•
Supplementary socket 12V	•	•
Manual Air Conditioning	0	0
"Climatronic Venieri" system	0	0
Ceiling lamp	•	•
Sun visor	•	•
Rear view mirrors	•	•
Heatable rear view mirrors	0	0
First-aid kit	0	0
Fire extinguisher 2kg	0	0
Seat belt	•	•
Instrumentation and dashboard with LCD display	•	•
Safety glass breaker	•	•

**SPECIAL EQUIPMENT**

Hydraulic or mechanical quick coupler	0	0
Cement mixing bucket	0	0
Multipurpose bucket (4 in 1)	0	0
Lifting forks	0	0
Asphalt and cement planer	0	0
Snow blower	0	0
Snow blade and "V" type snow blade	0	0
Angle-tilt dozer blade	0	0
Hand operating hammer	0	0
Polishing brush	0	0
Trencher	0	0
High tip bucket	0	0
High flow kit	0	0
Unpressurized return pipe	0	0
Double auxiliary line	0	0
Rear hydraulic line (single effect)	0	0



(2020) LP-463H563D\_A.GB proartigrafica.it



Via Piratello, 106 - 48022 Lugo (RA) - ITALY  
Tel. +39 0545 904411 Fax +39 0545 30389  
e-mail: [info@vf-venieri.com](mailto:info@vf-venieri.com) | [www.vf-venieri.com](http://www.vf-venieri.com)

**Spare Parts**  
Tel. +39 0545 904429 Fax +39 0545 24555  
e-mail: [ricambi@vf-venieri.com](mailto:ricambi@vf-venieri.com)