

DB 460



All pictures shown are for illustrative purposes only and may contain optional equipment.

MIXER SYSTEM

With a 4.0 m³ concrete yield, the DB 460 is unique in the world of self-loading concrete mixers and the best-selling model on the market. Agile and functional, equipped with reversible driver's seat, four-wheel drive and steering, tilting drum system (to facilitate casting of any kind of concrete), and 360° unloading, this vehicle guarantees an extremely high daily productivity in different construction site conditions. Featuring a special drum design that ensures optimal mix homogenisation, the DB 460 models are often equipped with the CBV 2.0 option (a FIORI GROUP proprietary system for production process management and control), making them a valid alternative to small and medium-sized batching plants. The unrivalled technology of the CBV 2.0 guarantees constancy, repeatability, and certifiability of the concrete produced and includes an option for connection to the HS/BS cement dispensers, thereby ensuring a controlled, accurate, fast, and documented process.

FIORI

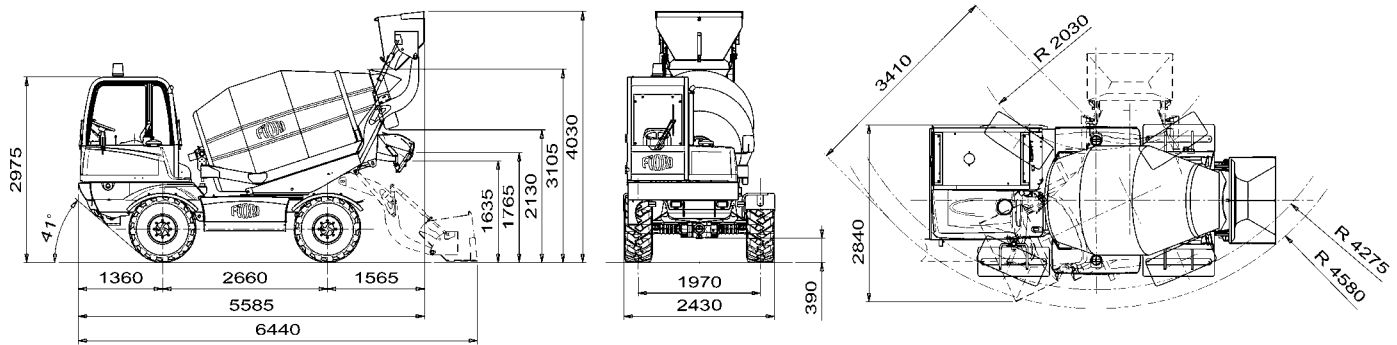

DIESEL ENGINE	No emission compliance	Stage IIIA / Tier 3	Tier 4 Final EPA	Stage V
Model :	PERKINS serie 1104	PERKINS serie 1104	KOHLER series KDI 3404 TCRSCR	PERKINS series 904J-E36TA
Type :	Turbo	Turbo Intercooler	Turbo Intercooler	Turbo Intercooler
Total displacement :	4400cc - 4 in linea	4400cc - 4 in line	3400cc - 4 in line	3600cc - 4 in line
Injection :	Mechanical control with direct injection	Mechanical control with direct injection	Electronic control with Common Rail	Electronic control with Common Rail
Aftertreatment sys.:	-	-	EGR + DOC + SCR	EGR + DOC + DPF + SCR
Cooling :	air water, dry air filter	air water, dry air filter	air water, dry air filter	air water, dry air filter
Maximum power :	82.5 kW (112 Hp)	83 kW (113 Hp)	90 kW (122 Hp)	90 kW (122 Hp)
Adj. power. :	82 kW (2400 rpm)	83 kW (2200 rpm)	90 kW (2200 rpm)	90 kW (2400 rpm)
Maximum torque :	404 Nm a 1400 rpm	418 Nm a 1400 rpm	500 Nm a 1400 rpm	500 Nm a 1500 rpm
Alternator :	12V - 65 A	12V - 65 A	12V - 90 A	12V - 120 A

ELECTRIC SYSTEM

Battery: 12 V - 132 Ah (600 A)
Road light system, rear working lights.

4X4 FOUR-WHEEL DRIVE

Hydrostatic "automotive" transmission with variable displacement pump and variable displacement hydraulic motor with electro-hydraulic control, and reverse gear control on the steering wheel.

Electro-hydraulically controlled mechanical gearbox for "working speed" and "road transfer" speed.

SPEED

4 forward gears 2 reverse gears
Ist 0 - 3.0 Km/h 0 - 3.0 Km/h
IInd 0 - 7.2 Km/h 0 - 3.0 Km/h
IIIrd 0 - 10.0 Km/h 0 - 10.0 Km/h
IVth 0 - 25.0 Km/h 0 - 10.0 Km/h
Traction / weight ratio 48%

AXLES AND WHEELS

Front, oscillating ($\pm 6^\circ$) and steering with planetary reduction gears on the wheel hubs.

Rear and steering with planetary reduction gears on the wheel hubs and flanged gearbox.

Tyres 18 -19.5 16PR

BRAKES

Internal oil-bath disc service and emergency brakes acting on the 4 wheels, activation with miniservo pump on independent dual circuit. Negative type parking brake, with internal oil-bath discs on the rear axle and electro-hydraulically controlled release.

STEERING

Assisted by means of load-sensing power steering with double displacement on 4 steering wheels; steering selection device for: 2 steering wheels, 4 steering wheels - crab steering.

WATER SYSTEM

"Self-priming" volumetric water pump with quick-suction.

Max. capacity: 250 litres/min.

Maximum head: 4 bar

Two connected tanks positioned opposite each other made of polyethylene with a total capacity of 870 litres.

Water feeding to the drum controlled by means of electromagnetic flow meter and fed litre reading the cabin display.

Water pump activation from the driver's seat and from the ground panel. Suction selection from the ground with quick-coupling pipes.

MIXING AND UNLOADING

Double-cone drum with double-spiral mixing screws and convex bottom.

Geometrical drum volume: 5050 litres

Drum rotation speed: 24 rpm.

Class S1 concrete produced as : 4.0 cu m

Counterframe mounted on "heavy-duty" ball fifth wheel, with 245° hydraulic rotation and automatic locking by means of negative brake.

Drum rotation by means of a piston pump with variable flow rate and an orbital hydraulic motor in closed circuit with infinitesimal electrical control positioned in the cabin and at the rear of the machine.

Drum raising up to the horizontal position by means of 2 double-acting jacks.

Unloading chute with hydraulic tilting by means of a double-acting jack and 180° rotation, independent from the mixing drum inclination. Removable chute, for direct unloading from hopper.

2 unloading chute extensions provided as standard equipment.

EQUIPMENT HYDRAULIC SYSTEM

Gear pump

Max. flow rate: 45 litres/min.

Maximum pressure: 180 bar

5-element distributor servo-controlled with multi-function joystick.

Chute lever distributor.

Aluminium heat exchanger for hydraulic oil cooling.

Pressurised closed-circuit intake with oil filter replaceable from the outside.

LOADER

Loading arms with self-compensated kinematic mechanism, double-acting loader lifting and return cylinders, electro-hydraulically controlled hatch with standard Tip-Off function.

Volumetric capacity: 560 litres

Number of loaderfuls per load: around 9 / 10

CAB

Closed cabin with heating system, designed in accordance with ROPS & FOPS 1st Level standards .

Sliding window on cabin door.

180° pivoting driving post. Anatomic seat with flexible suspension and height adjustment, seat belts.

LCD TV display with camera for rear visibility, optional/standard depending on engine type.

SERVICE REFILL CAPACITIES

Fuel tank in polyethylene, 95 litres

Total hydraulic system capacity: 125 litres

Engine oil: 7.96 kg

WEIGHTS

Operating weight 7300 kg

Max gross weight: 16500 kg

load-carrying capacity: 9200 kg