

GROUND DRILLING

- Compact high torque gearbox
- Highly efficient design with less moving parts
- Fitted with customized Eaton geroler hydraulic motor
- No drain required
- Extreme duty shaft locking system
- Innovative design allows the gearbox to go down the hole to maximise drilling depth without extensions
- Low maintenance with 5yr gear box and 3yr motor warranty

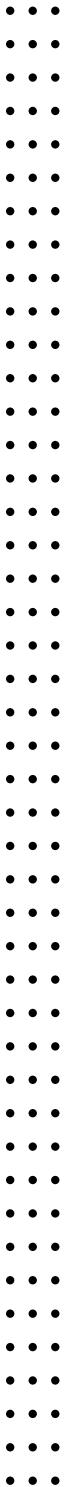

AUGERS: MINI EXCAVATOR/SKID STEER LOADER STD



AUGERS: EXCAVATOR/SKID STEER LOADER STD/HF



AUGERS: EXCAVATOR





5YR GEAR BOX WARRANTY

3YR MOTOR WARRANTY

Compact high torque gearbox
Highly efficient design with less moving parts
Fitted with customized Eaton geroler hydraulic motor
No drain required
Extreme duty shaft locking system
Innovative design allows the gearbox to go down the hole to maximise drilling depth without extentions
Low maintenance with 5yr gear box and 3yr motor warranty



EXCAVATOR HITCHES	
SINGLE PIN HITCH	
DIMENSIONS mm	
Ø 25	95/120
Ø 30	95/120
Ø 30	125/145
Ø 35	125/145
Ø 35	150/170

SKID STEER FRAME	
DESCRIPTION	
MPDD - MPDX2 - MPD3	

CRADLE HITCH	
DESCRIPTION	HITCH BASE PLATE mm
MPDD - MPDX2 - MPD3	200x150x25 250x225x25

EXTENSIONS	
DIMENSIONS mm	
Lenght 500 Ø 65	
Lenght 1000 Ø 65	
Lenght 1500 Ø 65	

DOUBLE PIN HITCH	
HITCH BASE PLATE mm	
200x150x25 250x225x25	

AUGERS 65 Ø MM ROUND HUB	
DIMENSIONS mm	MRC - MIXED TERRAIN AND ROCK Model
150x1200	MRC4-15
200x1200	MRC4-20
250x1200	MRC4-25
300x1200	MRC4-30
400x1200	MRC4-40
500x1200	MRC4-50
600x1200	MRC4-60

MODEL		MPDD	MPDX 2	MPD 3
Horse power [kw]		25	25	25
Max flow rate [lt/min]		15/45	30/50	45/75
Min/max pressure [bar]		125/240	125/240	175/240
Max torque [Nm]		1197	1320	3591
Rotation speed [rpm]		49/148	41/83	41/83
Motor type		gearbox + hydraulic motor		
Shaft [mm]		Ø 65	Ø 65	Ø 65
Weight [kg]		41	45	57
Excavator class		0,75-2	1,5-2,5	2-5
Tip for mixed terrain and rock	Tip kind	MRC4	MRC4	MRC4
	Max diameter	400	450	600

Included are no. 2 hydraulic hoses 1/2", L=2200 mm, quick couplings M/F F.P. 1/2"

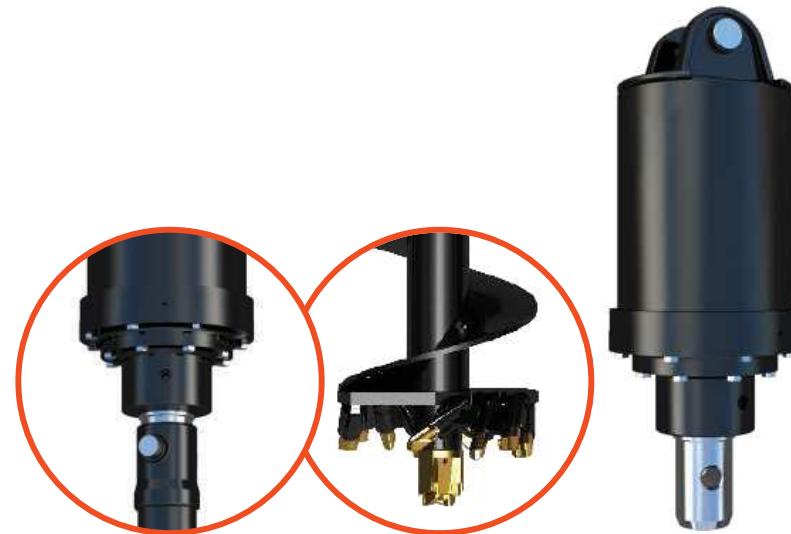



5YR GEAR BOX WARRANTY

3YR MOTOR WARRANTY

Compact high torque gearbox
 Highly efficient design with less moving parts
 Fitted with customized Eaton geroler hydraulic motor
 No drain required
 Extreme duty shaft locking system
 Innovative design allows the gearbox to go down the hole to maximise drilling depth without extentions
 Low maintenance with 5yr gear box and 3yr motor warranty



EXCAVATOR HITCHES	
SINGLE PIN HITCH	
DIMENSIONS mm	
Ø 40	150/170
Ø 45	150/170
Ø 45	175/200
Ø 50	150/170
Ø 50	175/200
Ø 50	210/230

SKID STEER FRAME	
DESCRIPTION	
MPD5/7	
MPD10 - MPD6/8 HF	

CRADLE HITCH	
DESCRIPTION	HITCH BASE PLATE mm
MPD5/7/10	250x250x25
6HF/8HF	275x250x25

EXTENSIONS	
DIMENSIONS mm	
Lenght 1000 Ø 75	
Lenght 1500 Ø 75	
Lenght 2000 Ø 75	

DOUBLE PIN HITCH	
HITCH BASE PLATE mm	
250x250x25 275x250x25	

AUGERS 75 Ø MM SQUARE HUB			
DIMENSIONS mm	MRC - MIXED TERRAIN AND ROCK		Model
	Model	Model	
150x1500	MRC6-15	600x1500	MRC6-60
200x1500	MRC6-20	750x1500	MRC6-75
250x1500	MRC6-25	900x1500	MRC6-90
300x1500	MRC6-30	1000x1500	MRC6-100
400x1500	MRC6-40	1200x1500	MRC6-120
500x1500	MRC6-50		

MODEL		MPD 5	MPD 7	MPD 10	MPD 6 HF	MPD 8 HF
Horse pwer [kw]		25	25	25	60	60
Max flow rate [lt/min]		60/95	75/115	85/115	60/150	80/200
Min/max pressure [bar]		175/240	175/240	175/240	175/240	175/240
Max torque [Nm]		5166	6048	8568	5670	7175
Rotation speed [rpm]		41/70	43/73	38/52	41/102	43/107
Motor type		gearbox + hydraulic motor				
Shaft [mm]		Ø 75	Ø 75	Ø 75	Ø 75	Ø 75
Weight [kg]		67	90	110	149	149
Excavator class		4-8	5-10	5-10	5-10	5-10
Tip for mixed terrain and rock	Tip kind	MRC6	MRC6	MRC6	MRC6	MRC6
	Max diameter	900	900	1000	1200	1200

Included are no. 2 hydraulic hoses 1/2", L=2200 mm, quick couplings M/F F.P. 1/2"





5YR GEAR BOX WARRANTY

3YR MOTOR WARRANTY

Compact high torque gearbox
 Highly efficient design with less moving parts
 Fitted with customized Eaton geroler hydraulic motor
 No drain required
 Extreme duty shaft locking system
 Innovative design allows the gearbox to go down the hole to maximise drilling depth without extentions
 Low maintenance with 5yr gear box and 3yr motor warranty



EXCAVATOR HITCHES
SINGLE PIN HITCH DIMENSIONS mm
Ø 65 mm
Ø 70 mm
Ø 75 mm

EXTENSIONS
DIMENSIONS mm
Lenght 1000 Ø 75
Lenght 1500 Ø 75
Lenght 2000 Ø 75
Lenght 2500 Ø 75

CRADLE HITCH	
DESCRIPTION	HITCH BASE PLATE mm
MPD18/22	200x150x25 250x225x25

DOUBLE PIN HITCH
HITCH BASE PLATE mm
325x300x25

AUGERS 75 Ø MM SQUARE HUB			
DIMENSIONS mm	MRC - MIXED TERRAIN AND ROCK		
	Model		Model
200x1500	MRC8-20	750x1500	MRC8-75
250x1500	MRC8-25	900x1500	MRC8-90
300x1500	MRC8-30	1000x1500	MRC8-100
400x1500	MRC8-40	1200x1500	MRC8-120
500x1500	MRC8-50	1500x1500	MRC8-150
600x1500	MRC8-60		

MODEL		MPD 18	MPD 22
Horse power [kw]		60	60
Max flow rate [lt/min]		130/230	140/230
Min/max pressure [bar]		175/240	175/240
Max torque [Nm]		17620	22257
Rotation speed [rpm]		26/50	21/40
Motor type		gearbox + hydraulic motor	
Shaft [mm]		Ø 75	Ø 75
Weight [kg]		176	176
Excavator class		10-20	10-20
Tip for mixed terrain and rock	Tip kind	MRC8	MRC8
	Max diameter	1500	1500

Included are no. 2 hydraulic hoses 1/2", L=2200 mm, quick couplings M/F F.P. 1/2"



HOW TO ORDER A DRIVE UNIT

WHEN ORDERING A DRIVE UNIT, CHOOSE ONE ITEM FROM EACH CATEGORY

1 DRIVE UNITS

2,2 m hoses & couplers - linkage block and pin included (from MPDD to MPD3)
3 m (from MPD5 to MPD22)

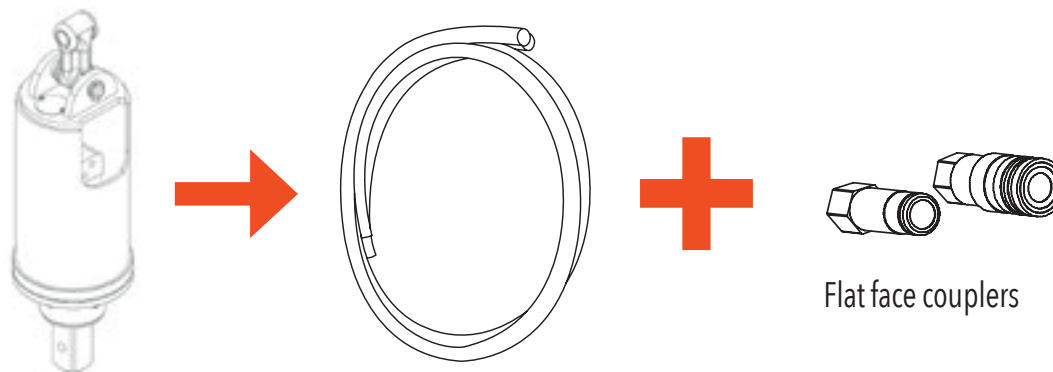

2 HITCH OR FRAME

Options available

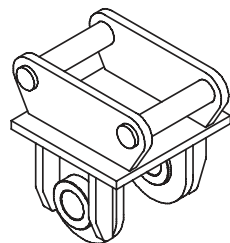

Single or double pin hitch

OR

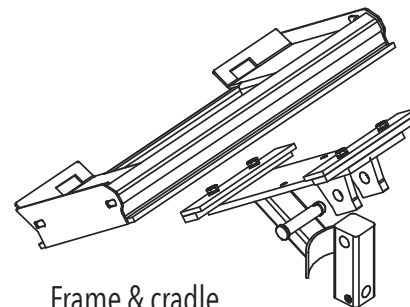

Frame & cradle

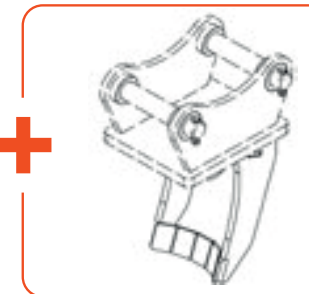

Cradle hitch
(recommended)

3 EXTENSIONS

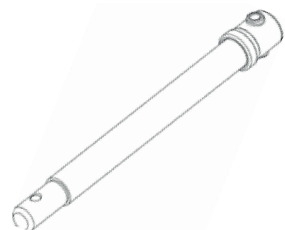

No.1 pin included

4 AUGERS

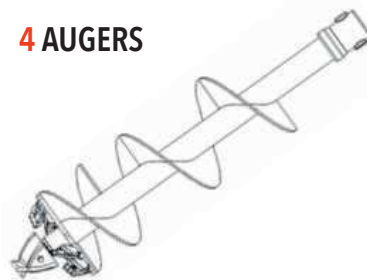

No.1 pin + kit for mixed terrain and rock

SPARE WEAR PART UNITS

(tool + pilots recommended)

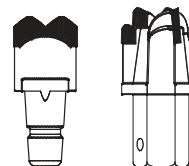

Spare wear part kits, available included outer teeth, inner teeth and nut&bolt



